

HONDA

INSTALLATION INSTRUCTIONS

Accessory
RIGHT PANNIER CASE
 P/N 08L75-MKS-E00
LEFT PANNIER CASE
 P/N 08L76-MKS-E00

Application
CRF1100A/A2/A4/D/D2/D4

Publication No.
MII
 Issue Date
June 2021

Honda Dealer: Please give a copy of these instructions to your customer.

PARTS LIST

<Right pannier case>

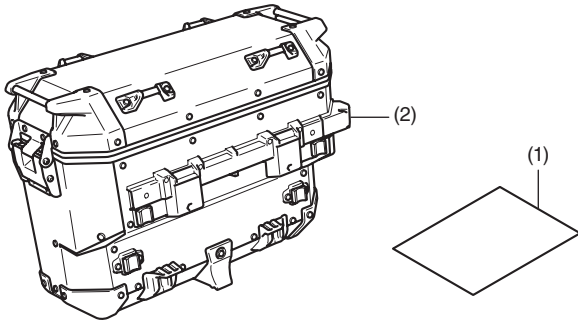

| No. | Description | Qty |
|-----|--------------------|-----|
| (1) | URL paper | 1 |
| (2) | Right pannier case | 1 |

<Left pannier case>

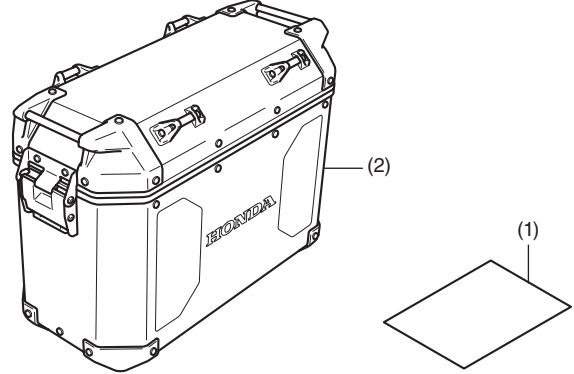

| No. | Description | Qty |
|-----|-------------------|-----|
| (1) | URL paper | 1 |
| (2) | Left pannier case | 1 |

1 KEY INNER CYLINDER (Wave key type)

- Do not use the [] slots.

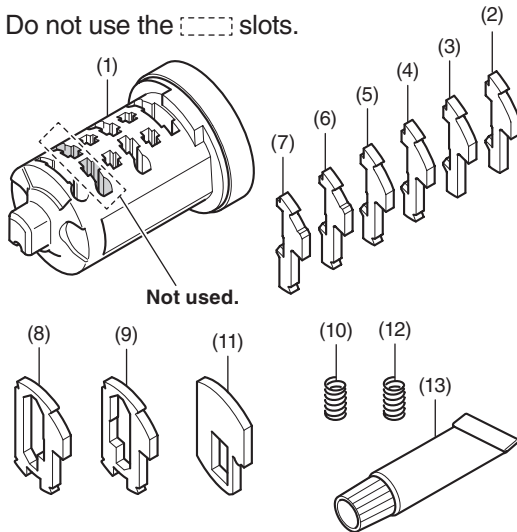

| No. | Description | Qty |
|------|------------------------|-----|
| (1) | Inner cylinder | 1 |
| (2) | No.1 tumbler | 6 |
| (3) | No.2 tumbler | 6 |
| (4) | No.3 tumbler | 6 |
| (5) | No.4 tumbler | 6 |
| (6) | No.5 tumbler | 6 |
| (7) | No.6 tumbler | 6 |
| (8) | Sub-lock tumbler A | 1 |
| (9) | Sub-lock tumbler B | 1 |
| (10) | Spring (Silver) | 13 |
| (11) | Stopper tumbler | 2 |
| (12) | Stopper spring (Black) | 2 |
| (13) | Grease | 1 |

1 KEY INNER CYLINDER (Wave key type)

- Do not use the [] slots.

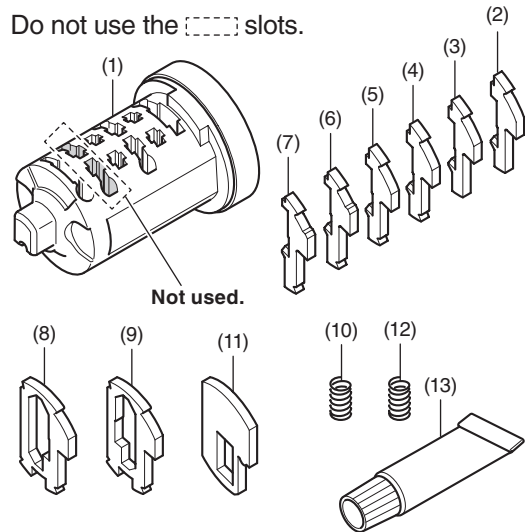

| No. | Description | Qty |
|------|------------------------|-----|
| (1) | Inner cylinder | 1 |
| (2) | No.1 tumbler | 6 |
| (3) | No.2 tumbler | 6 |
| (4) | No.3 tumbler | 6 |
| (5) | No.4 tumbler | 6 |
| (6) | No.5 tumbler | 6 |
| (7) | No.6 tumbler | 6 |
| (8) | Sub-lock tumbler A | 1 |
| (9) | Sub-lock tumbler B | 1 |
| (10) | Spring (Silver) | 13 |
| (11) | Stopper tumbler | 2 |
| (12) | Stopper spring (Black) | 2 |
| (13) | Grease | 1 |

PANNIER STAY
Sold separately

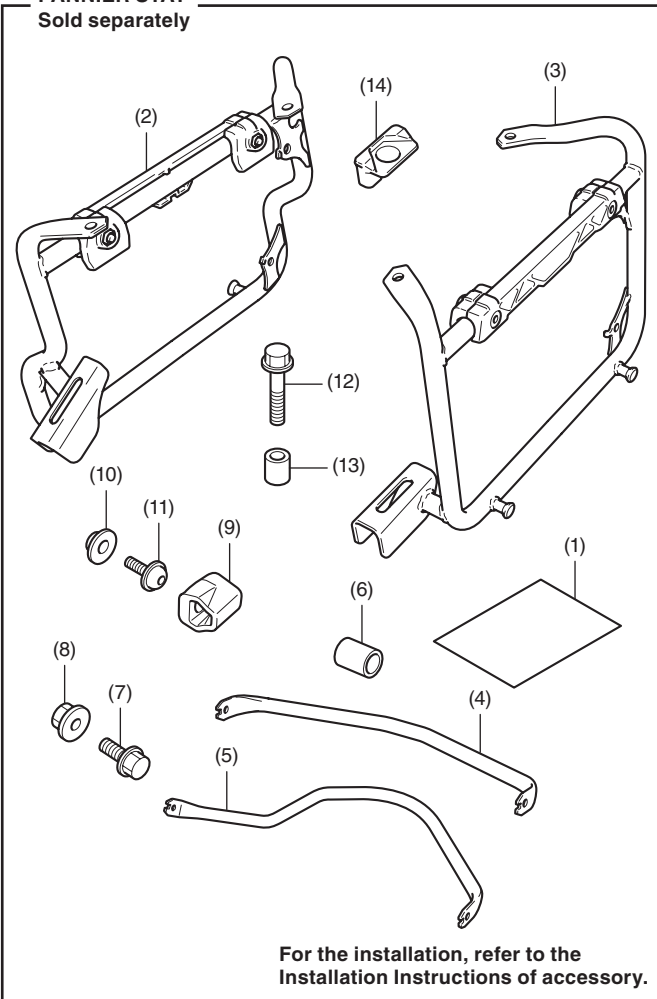

For the installation, refer to the Installation Instructions of accessory.

| No. | Description | Qty |
|------|---------------------|-----|
| (1) | URL paper | 1 |
| (2) | Right pannier stay | 1 |
| (3) | Left pannier stay | 1 |
| (4) | Upper cross pipe | 1 |
| (5) | Lower cross pipe | 1 |
| (6) | Tube | 1 |
| (7) | 8 mm SH flange bolt | 4 |
| (8) | 8 mm flange nut | 4 |
| (9) | Rubber | 2 |
| (10) | Flange collar | 2 |
| (11) | 5 mm socket bolt | 2 |
| (12) | 8 mm flange bolt | 4 |
| (13) | Collar | 4 |
| (14) | Pannier stay cap | 4 |

MAXIMUM LOADING CAPACITY

- The weight of the cargo must not exceed the following maximum loading capacity:

| Maximum Loading Capacity | |
|--------------------------|-------------------|
| Right pannier case | 10.0 kg (22.0 lb) |
| Left pannier case | 10.0 kg (22.0 lb) |

< Notes regarding the key cylinder >

- This product is used to assemble a key cylinder matching the motorcycle key by combining six types of tumblers.
- When this key cylinder is installed in a box or similar equipment, the installed equipment can be operated with the motorcycle key.

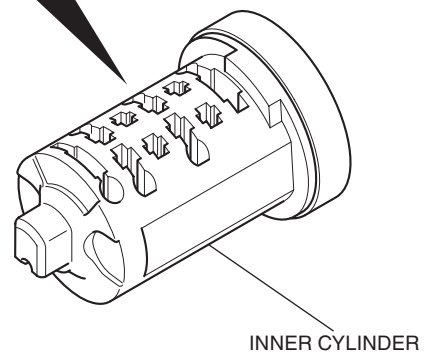
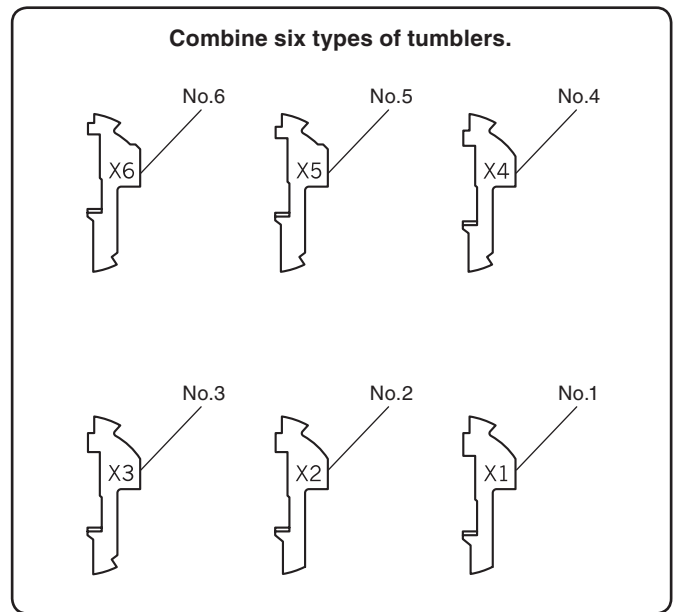

INSTALLATION

1. The two sub-lock tumbler types shown are provided.
 - The  part has a different slot for each of the two sub-lock tumbler types.
 - As the tumblers are small, keep them in the bag until they are used.

SUB-LOCK TUMBLER A

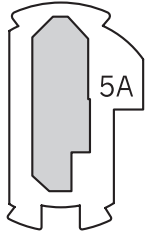

SUB-LOCK TUMBLER B

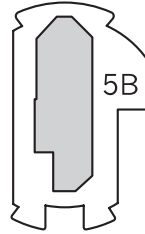

The stopper tumbler will be used later.

STOPPER TUMBLER



2. The six tumbler types shown are provided.
 - The  part has a different width for each of the six tumbler types.
 - As the tumblers are small, keep them in the bag until they are used.

No.6 No.5 No.4 No.3 No.2 No.1

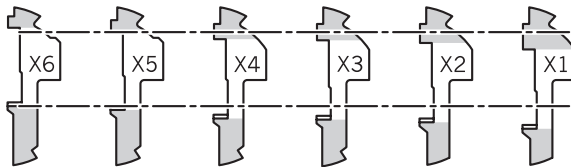

3. Install the tumblers and springs (silver) as shown.
- **First install four No.1 tumblers.**
 - **Note the installed tumbler to below chart.**

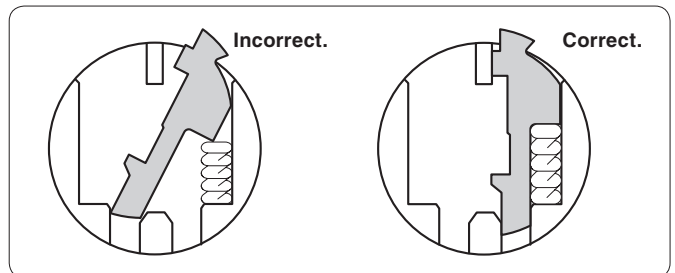
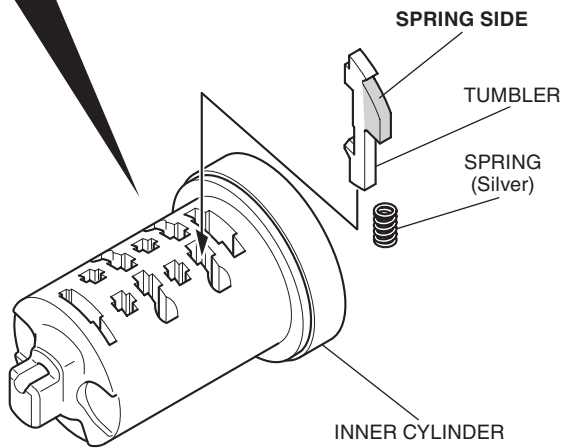
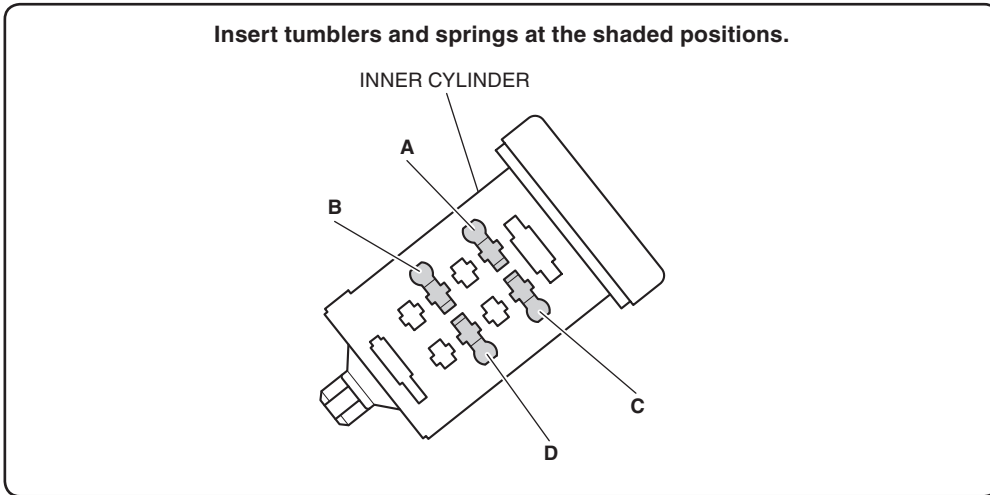

| | Position A | Position B | Position C | Position D |
|---------------------|------------|------------|------------|------------|
| No.1 tumbler | | | | |
| No.2 tumbler | | | | |
| No.3 tumbler | | | | |
| No.4 tumbler | | | | |
| No.5 tumbler | | | | |
| No.6 tumbler | | | | |

- Insert the key as shown.
 - Lightly press down on the tumblers from above, then insert the key.

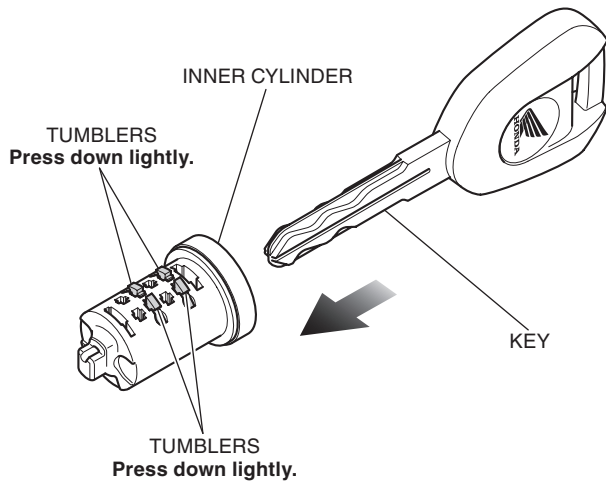

- Confirm that some tumblers are projecting. Mark the positions of the projected tumblers.
 - The positions where tumblers project and the projecting height differ according to the key.

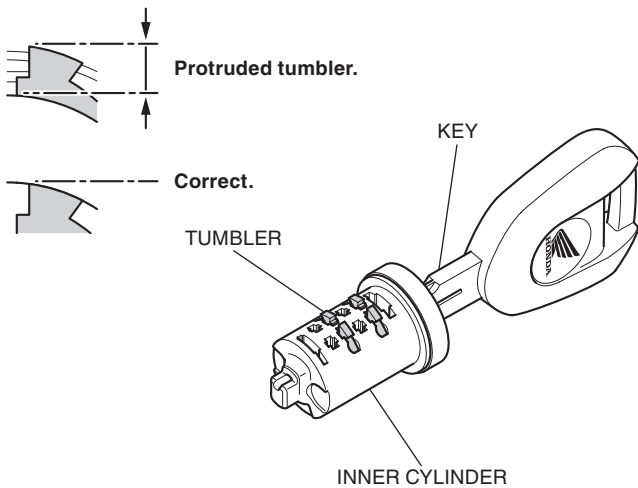

- Press down lightly on the tumbler, pull the key out.
 - The tumbler spring may jump out when the tumbler is not pressed down lightly.

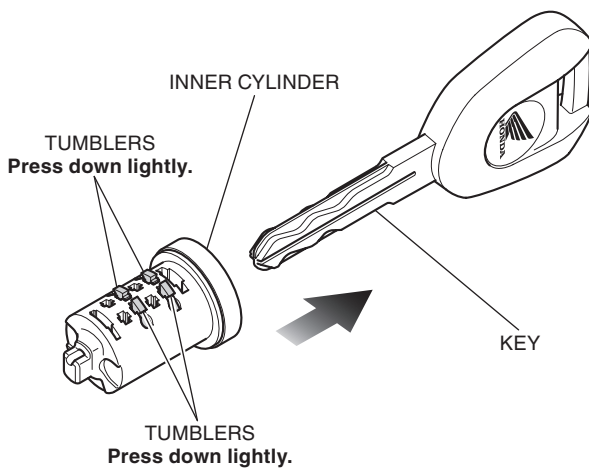

- Pull out the projecting tumbler(s).
 - Leave the spring(s) installed.

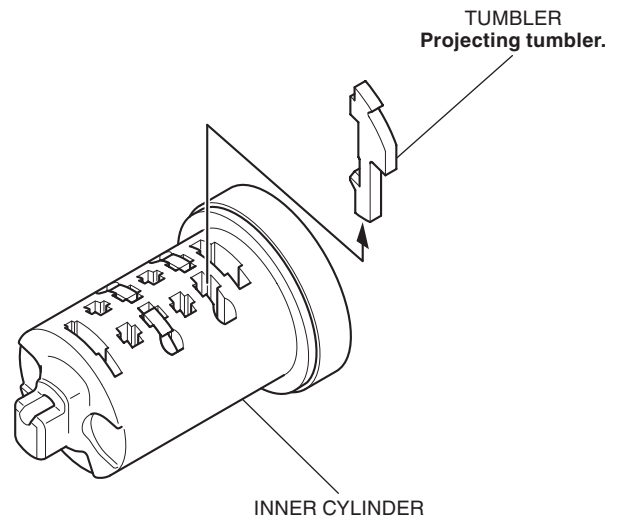

- Insert a different tumbler(s) at the marked positions.
 - Use a tumbler of young number one stage.

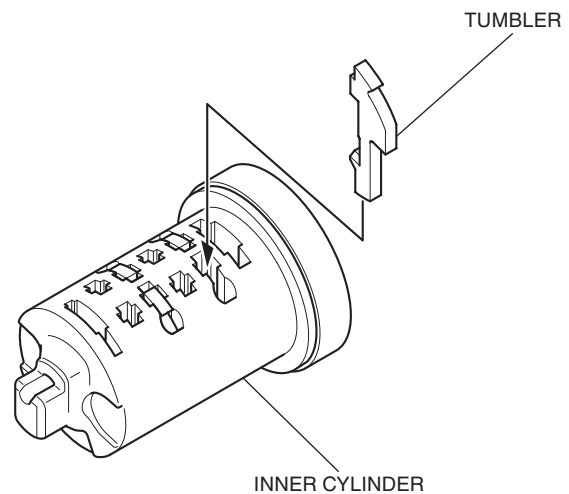

- Repeat steps 4 to 8, inserting different tumblers at the marked positions until no tumblers are projected.
 - Lightly press down on the tumblers from above, then insert the key.

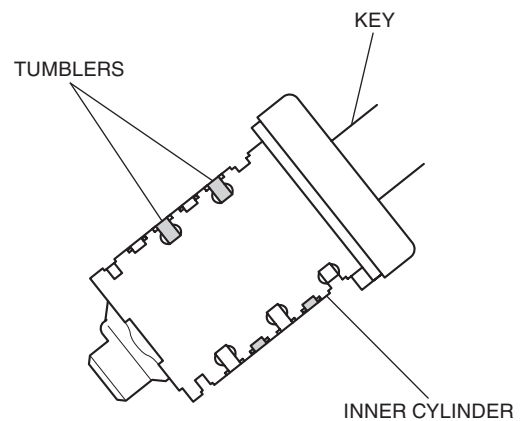

10. Install the tumblers and springs (silver) to the reverse side inner cylinder as shown.

- **First install two No.1 tumblers.**

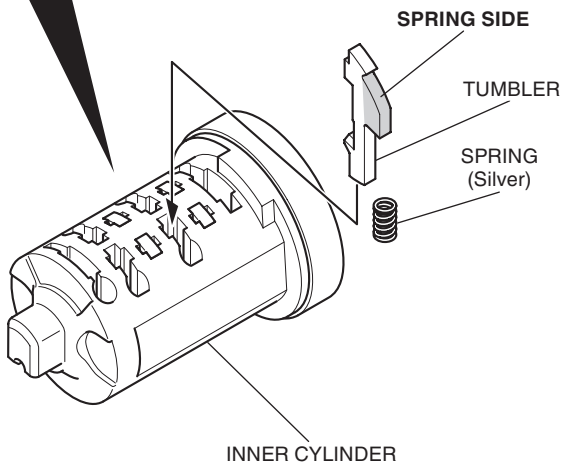
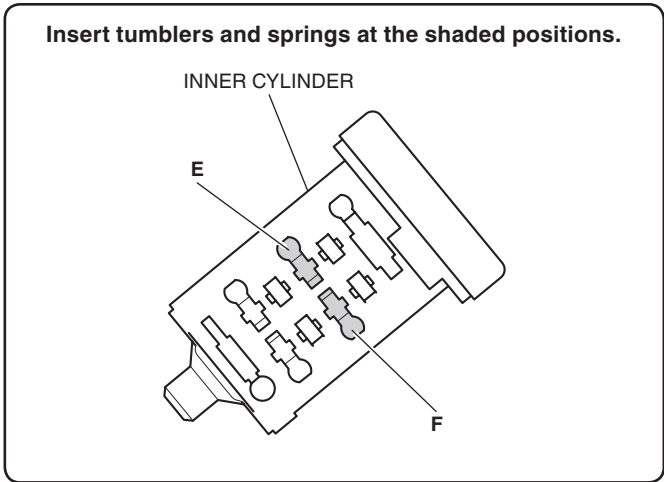

- **Note the installed tumbler to below chart.**

| | Position E | Position F |
|--------------|------------|------------|
| No.1 tumbler | | |
| No.2 tumbler | | |
| No.3 tumbler | | |
| No.4 tumbler | | |
| No.5 tumbler | | |
| No.6 tumbler | | |

11. Use steps 4 through 8 to assemble the reverse side inner cylinder in the same manner.

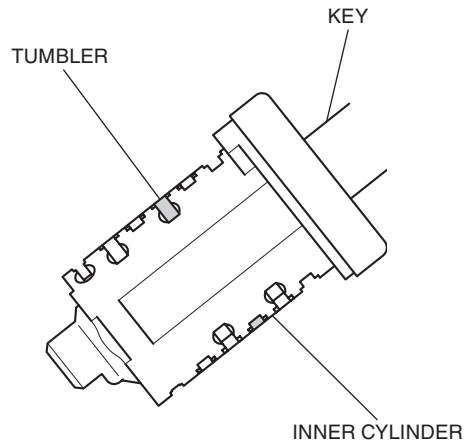

12. Install the sub-lock tumbler as shown.

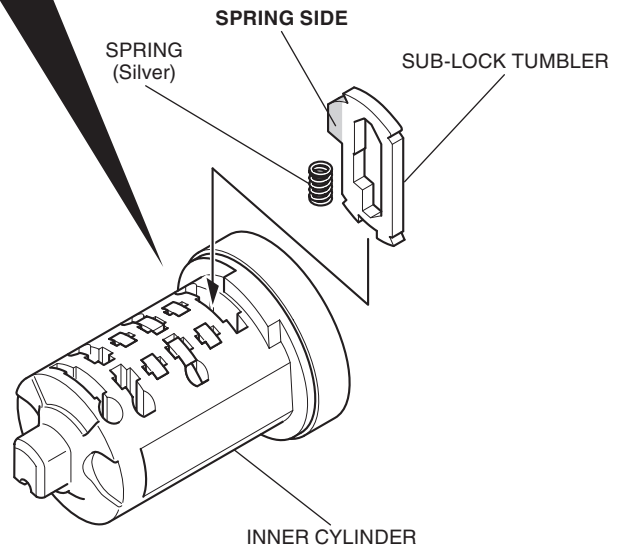
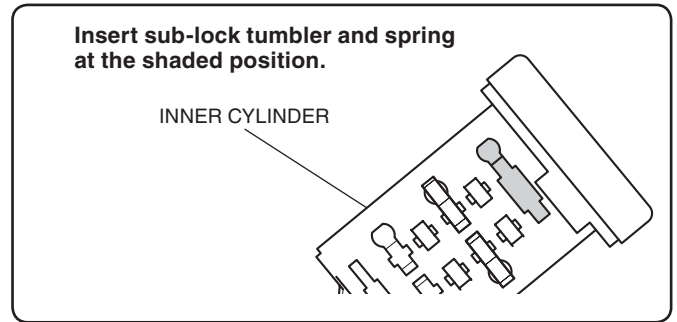

- **Note the installed tumbler to below chart.**

| | |
|--------------------|--|
| Sub-lock tumbler A | |
| Sub-lock tumbler B | |

13. Confirm that sub-lock tumbler is not projecting.
- **If the tumbler is projected, change the another sub-lock tumbler and recheck.**

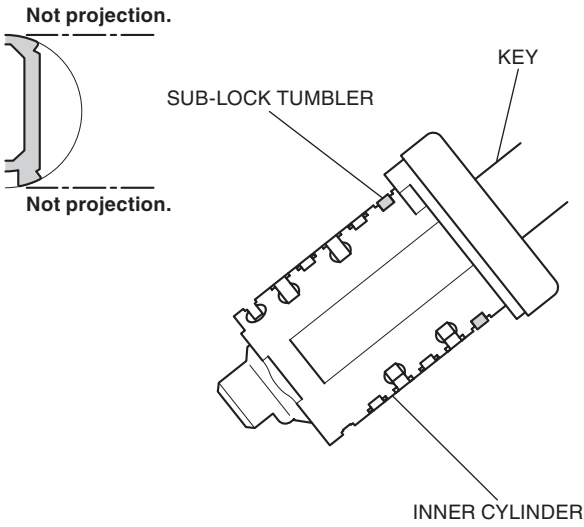

14. Remove the cap as shown.

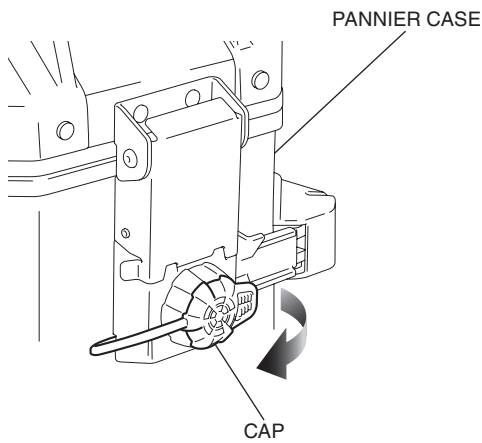

15. Insert the assembled inner cylinder into the key cylinder as shown.
- **Confirm the inner cylinder turns clockwise smoothly.**

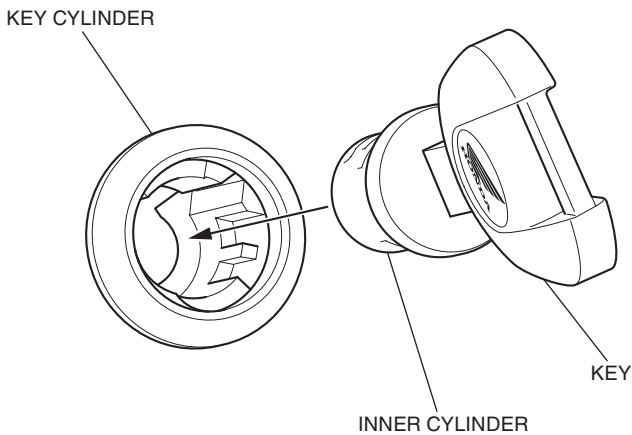

16. Pull out the inner cylinder.
17. Press down lightly on the tumblers and pull out the key.

18. Install the stopper tumbler and stopper spring (black) as shown.

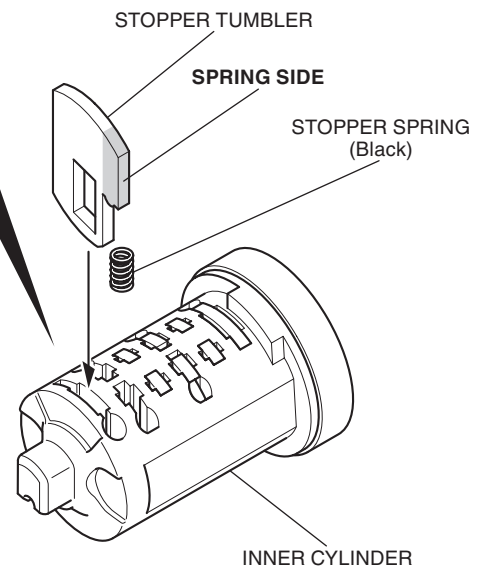
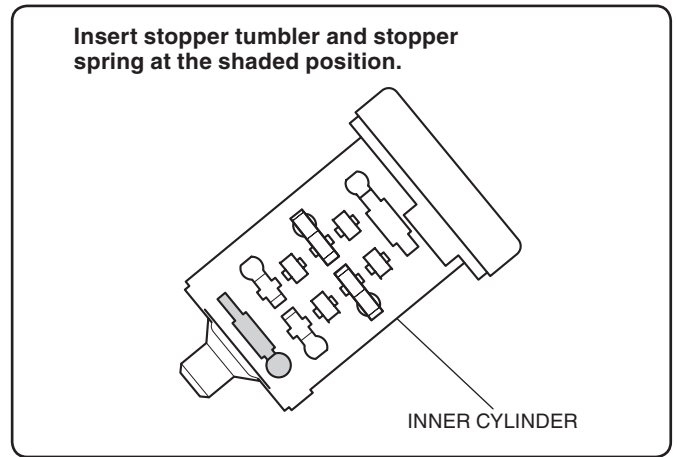

19. Insert the key as shown.
- **Lightly press down on the tumblers from above, then insert the key.**
 - **Confirm that the stopper tumbler jumps out.**

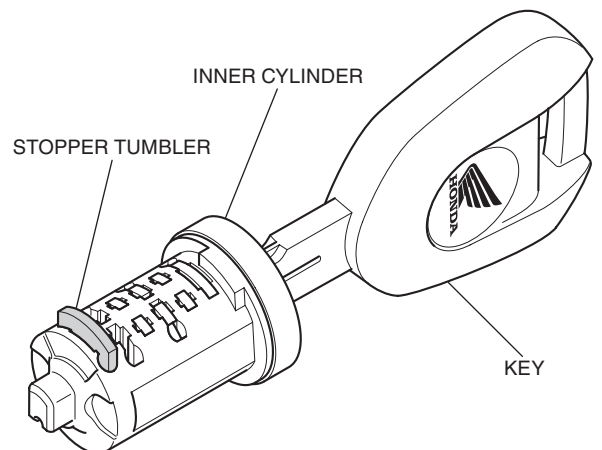

20. Apply grease to the shaded areas as shown.

- Apply to the tumbler and to the outer circumference of the inner cylinder.
- Only use the supplied grease.

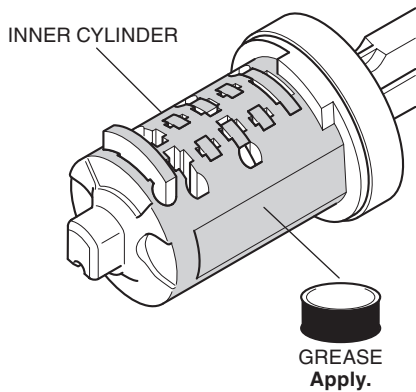

21. Install the inner cylinder by sliding the stopper tumbler along the slide guide while rotating it.

- If the inner cylinder cannot be inserted, again confirm that no tumblers other than the stopper tumbler have jumped out.

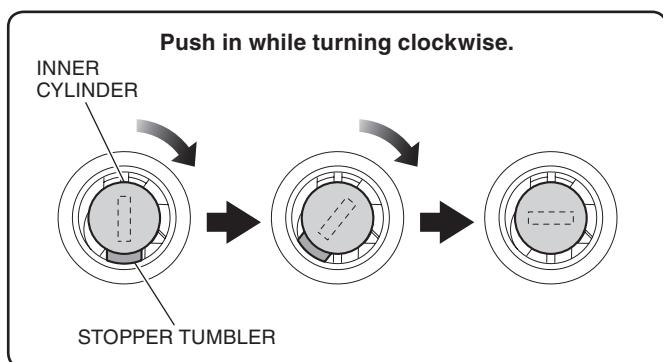
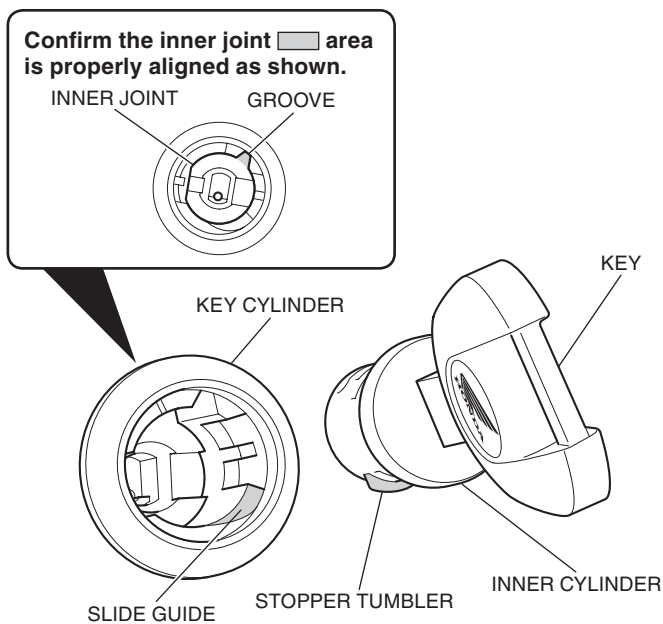

22. Draw out the key and check that the inner cylinder does not come out.

23. Install the inner cylinder to other pannier case in the same manner.

FOR USE OF THE PANNIERS

⚠ CAUTION

- To prevent burns, allow the engine, exhaust system, radiator, etc., to cool before installing and removing the accessory.

How to Open the Panniers

1. Remove the cap as shown.

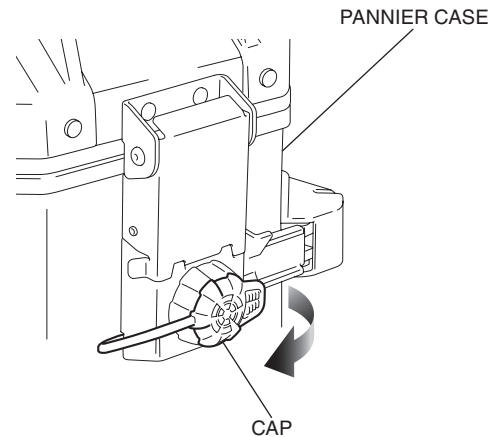

2. Insert the key and release the lock by turning the key clockwise.

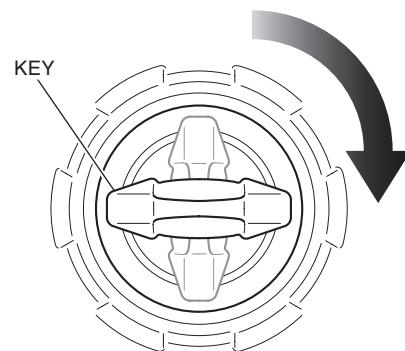

3. Pull the hinge up as shown.

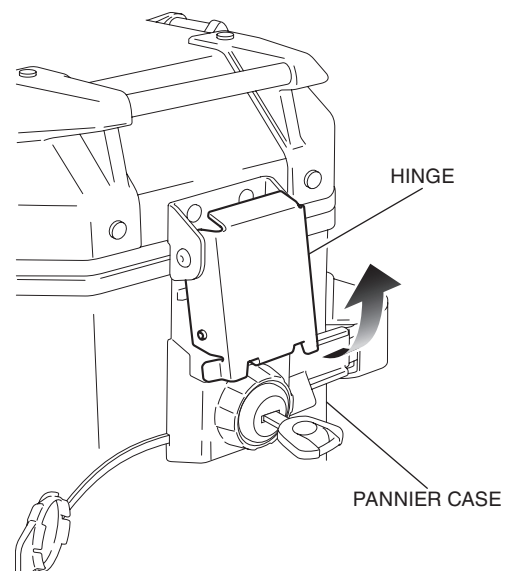

4. Release the hinge from hinge bar as shown.

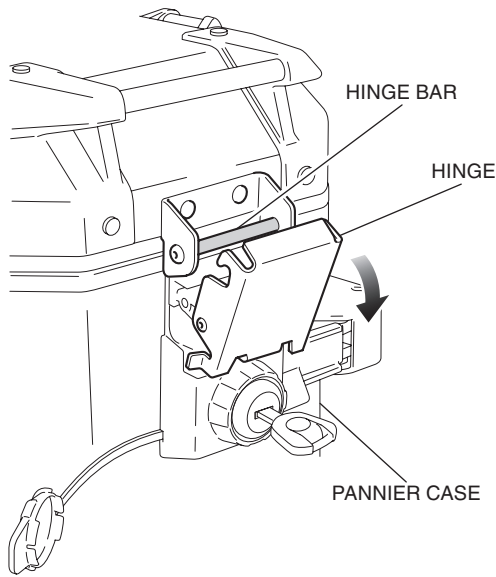

5. Open the lid as shown.

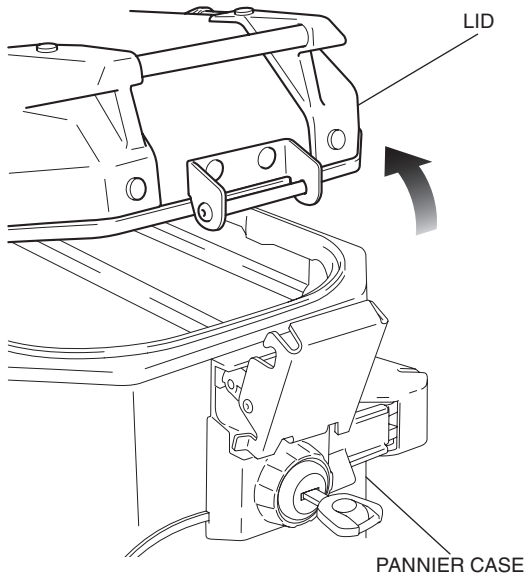

How to Close the Panniers

1. Close and lock the pannier case in reverse order of opening.
 - **Be careful not to have the stored item pinched when the pannier case is closed.**

How to Install the Panniers

1. Install the pannier stay (sold separately).
2. Install the left pannier case as shown.
 - **First install the two bosses, then install the two cams.**
 - **Installation can be done with the key position is in lock or unlock.**
 - **Installation can be done without inserting the key.**
 - **When the pannier case can not be installed, operate the lever and reinstall it.**

<Left side>

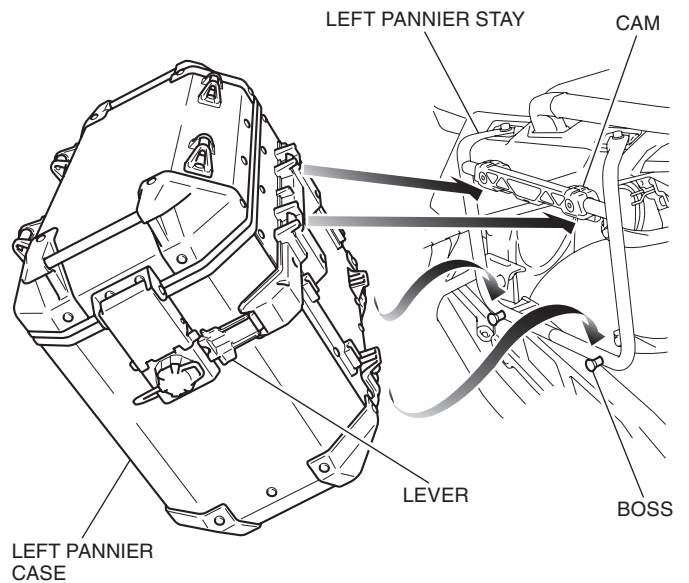

3. Make sure that the indicators in front and behind the pannier stay are green.
 - **When the indicator is red, the pannier case is not securely installed. Remove the pannier case and reinstall it.**

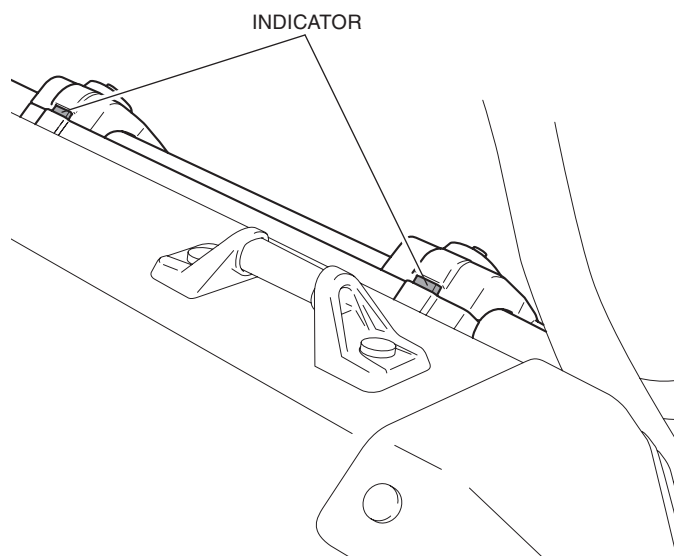

4. If the key is inserted, pull it out and install the cap.
5. Check that the left pannier case is installed securely by swinging the left pannier case taking care not to fall the motorcycle down.
 - **The left pannier case can come off during riding unless it is mounted securely.**

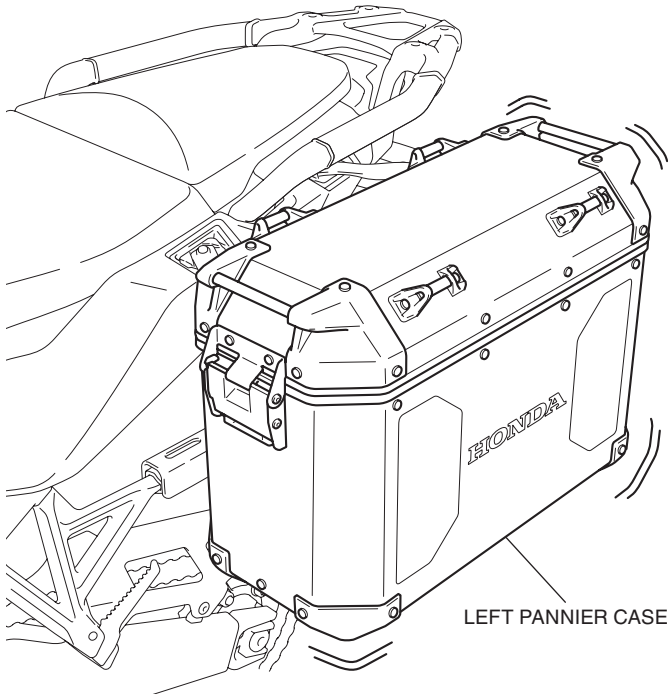

6. Install the right pannier case in the same manner as the left side.

How to Remove the Panniers

1. Remove the cap as shown.

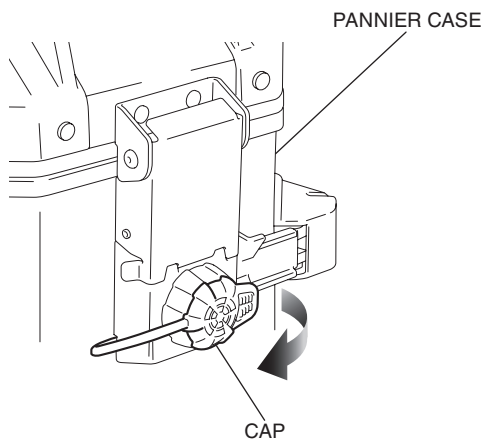

2. Insert the key and release the lock by turning the key clockwise.

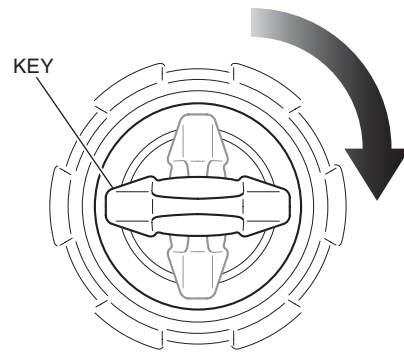

3. Pull the lever as shown.
 - **Make sure that the indicator of pannier stay is red after pulling the lever.**

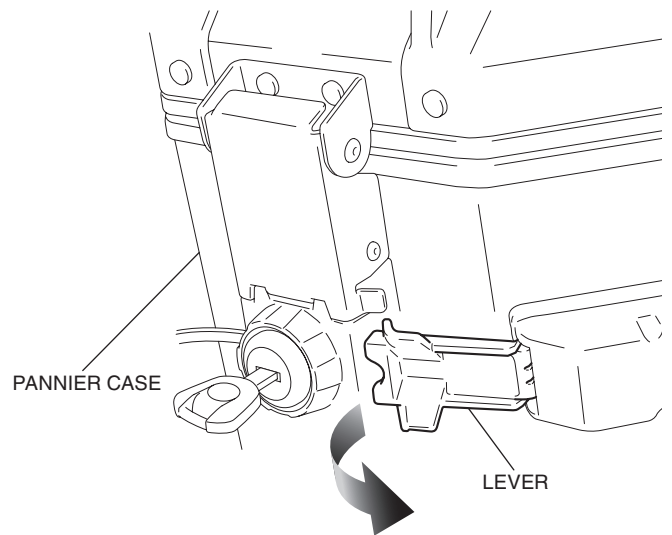

4. Remove the panniers in the reverse order of installation.

How to Store the Pannier Inner bag

1. Open the pannier case and store the pannier inner bag.
2. Close the pannier case.
 - **Be careful not to have the stored item pinched when the pannier case is closed.**